

MODEL 1730 PLUNGER PUMP



15.8 GPM | 1,500 PSI

The New Standard in Direct Drive Pumps

Every once in a while a product is introduced that changes the norm, and the Model 1730 is just that. Introducing the first direct-driven triplex pump capable of a commanding and unequalled 15.8 gpm.

Cat Pumps engineers have optimized every detail to produce an innovative pump design with excellent service life. With a bell housing the 1730 easily attaches to a "C" face motor (1750 rpm), allowing for a space-saving footprint that fits almost anywhere. Bell housings are available for NEMA or IEC Motor applications. And being direct-driven, it's simple to install and maintain since there are no belts, pulleys or baseplates.

Designed for continuous-duty applications, the Model 1730 pump is what industry leaders demand — a dependable, high-quality product backed by world-class customer service, training and support.

Typical Applications

- Car Wash
- Central Cleaning System
- Misting
- Conveyor Belt Wash
- High-Pressure Machine Tool Coolant
- Tank Cleaning
- Equipment Wash-Down

Direct Drive Features

- Ease of assembly reduces time and labor costs
- Compact direct mounting reduces space requirement
- Eliminates belt selection, sizing and adjustment
- Bell housings are cast from lightweight, high-strength aluminum alloy



MOTOR SIZE	BELL HOUSING	FLEX COUPLER
213/215TC	76215.15FR	8388
254/256TC	76256.15FR	8382
284/286TC	76286.15FR	8383

Contact Cat Pumps for IEC Bell Housing and Flex Coupler options.

Specifications

	U.S. Measure	Metric Measure
Flow	15.8 gpm	60.0 lpm
Pressure	1500 psi	103 bar
Pump RPM*	1750 rpm	1750 rpm
Inlet Pressure Range	Flooded to 70 psi	Flooded to 4.8 bar
Max Liquid Temperature	140° F	60° C
Inlet Ports (2)	1" NPT(F)	1" NPT(F)
Discharge Ports (2)	¾" NPT(F)	¾" NPT(F)
Weight	55 lbs	24.9 kg
Dimensions	17.24 x 12.99 x 7.40"	438 x 330 x 188 mm

*Pump minimum is 100 RPM.

Dimensions

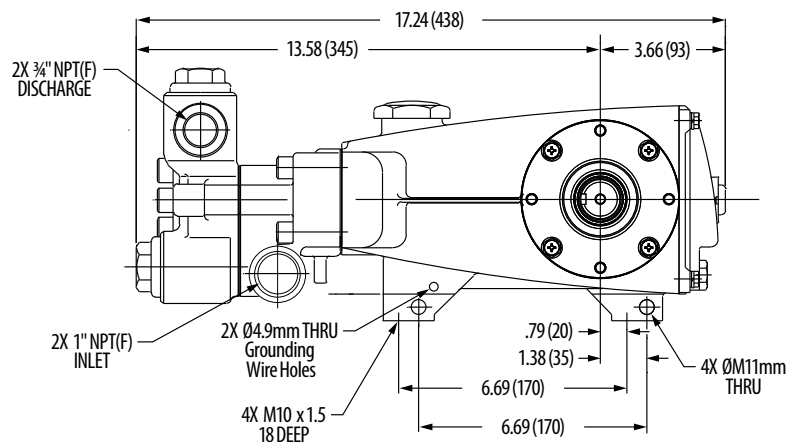
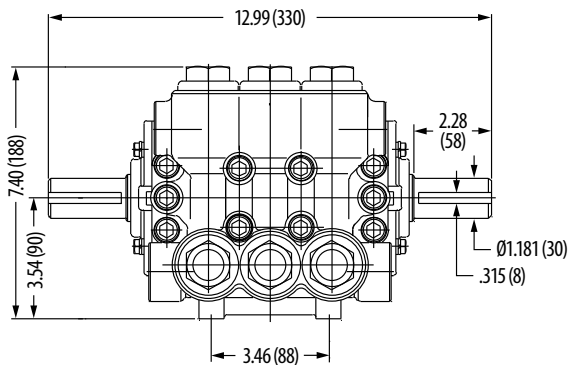

Popular Accessories



Unloader

PN 7537
1 – 21 GPM
230 – 2600 PSI



Pop-off Valve

PN 9940
0 – 25 GPM
1000 – 4000 PSI



Pressure Gauge

PN 6088
0 – 3000 PSI



Pulsation Dampener

PN 6018
Up to 40 gpm
0 – 3000 psi
NBR Bladder



Crankcase Oil

PN 6107
21 oz. Bottle
Specially Formulated for
Extended Protection

Neem contact op met Cat Pumps voor prijzen of meer informatie op info@catpumps.nl of +31(0)50-8200963



PIJTTERSEN

Pijtersen B.V.
Beneluxweg 33
9636 HV Zuidbroek
Tel.: +31(0)50-8200963

KvK 01013855
BIC RABONL2U
BTW NL002166811B01
IBAN NL24 RABO 0353 2970 97

